

Dimension sheet „Butterfly Valves“

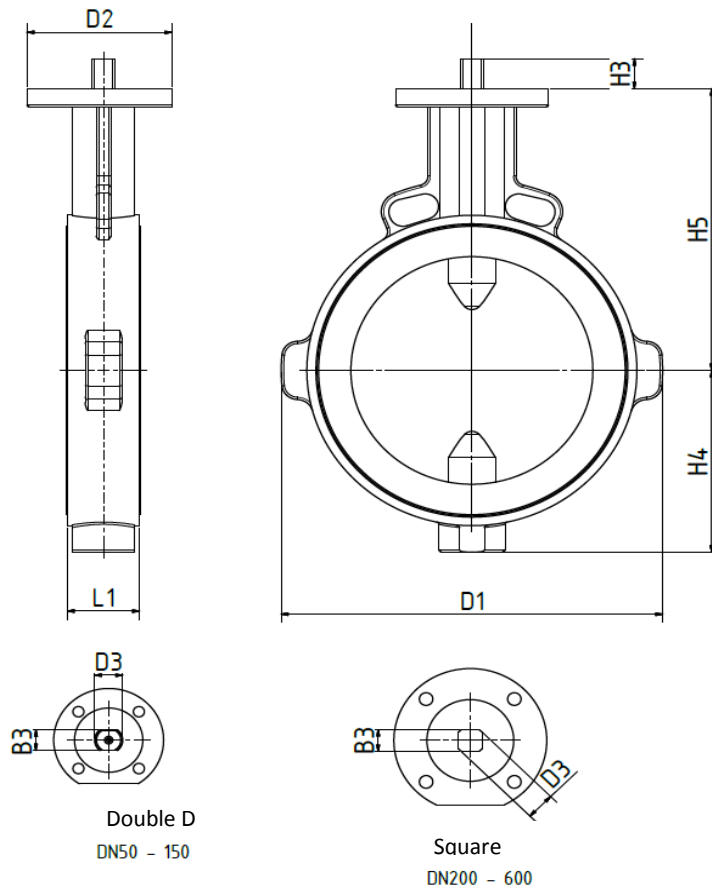

CENTER TECH Pegasus Typ AW with bare shaft

Dimensions and weight



Size DN	ISO Flange	FTF L1	D1	D2	D3	B3	H3	H4	H5	weight
mm		mm	mm	mm	mm	mm	mm	mm	mm	Kg.
40*	F05	33	142	65	13	9	19	53	94	3
50	F07	43	104	90	14	11	19	56	130	3
65	F07	46	128	90	14	11	19	67	146	4
80	F07	46	144	90	14	11	19	84	165	5
100	F07	52	164	90	18	14	25	100	185	7
125	F07	56	194	90	18	14	25	110	202	8
150	F07	56	220	90	22	17	30	125	217	10
200	F10	60	274	125	24	19	26	158	245	17
250	F10	68	330	125	28	22	30	190	270	25
300	F10	78	380	125	28	22	30	225	308	37
350*	F12	**92	571	150	36	27	37	256	330	87
400*	F12	102	643	150	36	27	37	292	365	107
450*	F14	114	684	175	48	36	50	311	400	152
500*	F14	127	745	175	48	36	50	340	435	185
600*	F16	154	863	210	60	46	64	398	510	254

* Housing design: End fitting, threaded holes drilled through
 ** Not compliant with EN 558-1, series 20

Other diameter on request